

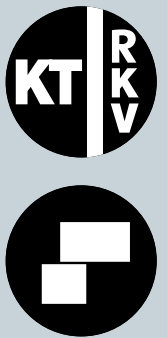

Hahn KT-RKV

- D** Universelles Rollenband für Kunststofftüren
- F** Paumelle cylindrique universelle pour portes PVC
- GB** Universal butt hinge for PVC-U doors



Einbauanleitung · Notice de montage · Installation instructions



Einzelteile · Pièces détachées · Single Parts

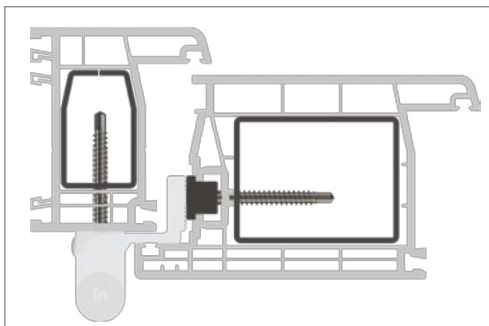
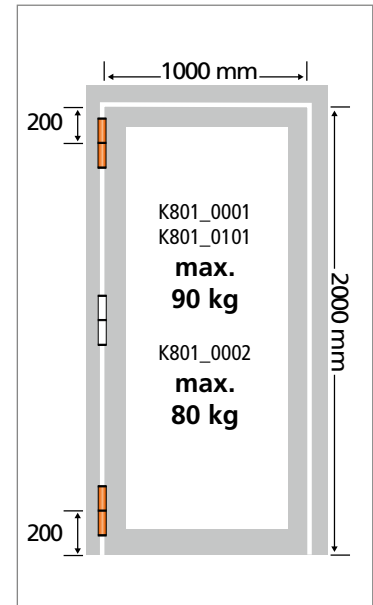

Lagerbuchse aus wartungsfreiem Kunststoff
 – **keinesfalls schmieren!**

Douille en matière plastique ne requérant aucun
 entretien – **ne graisser en aucun cas !**

Bearing bushes made of maintenance-free PVC
 – **do not lubricate!**

Montage des Türbands · Montage de la paumelle · Installing the hinge

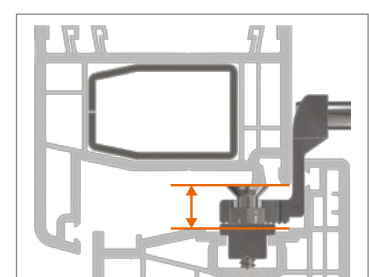
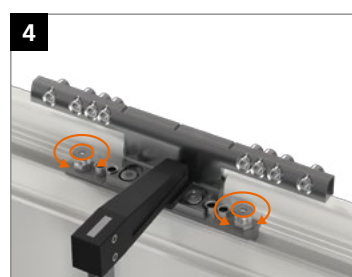
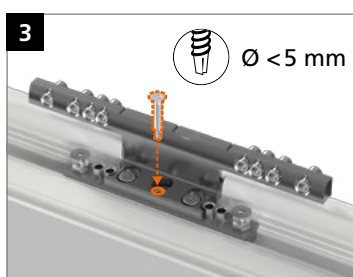
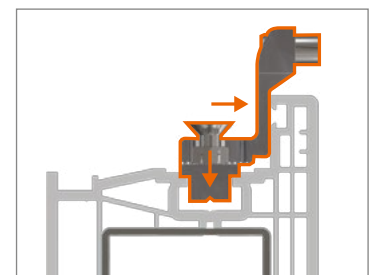
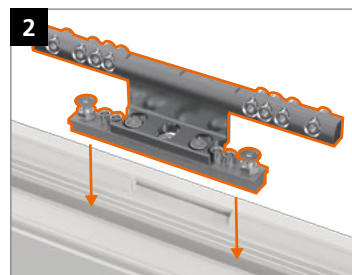
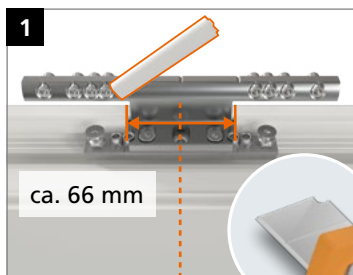

Montage des Türbands · Montage de la paumelle · Installing the hinge

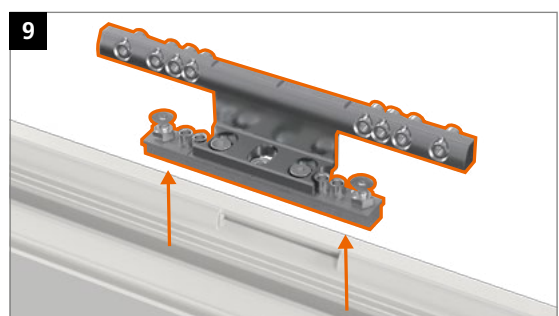
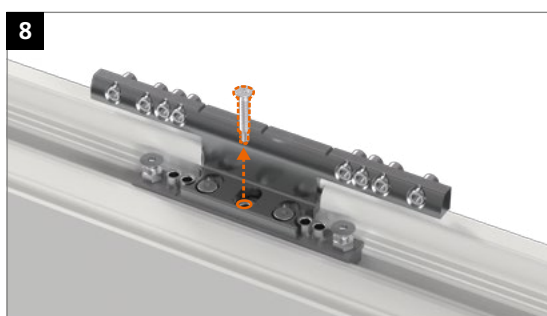
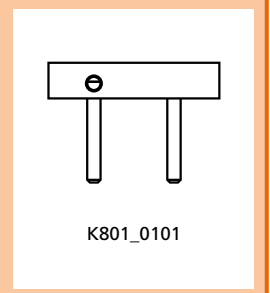
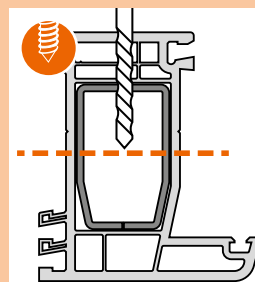
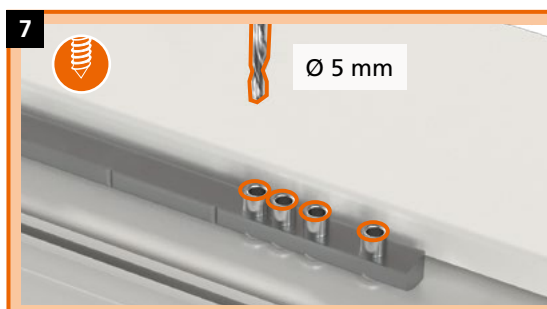
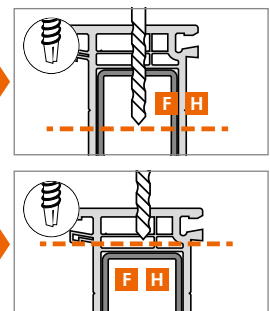
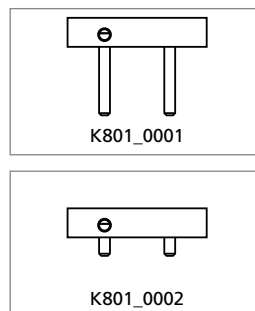
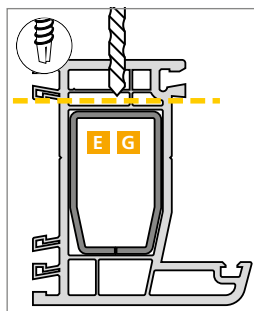
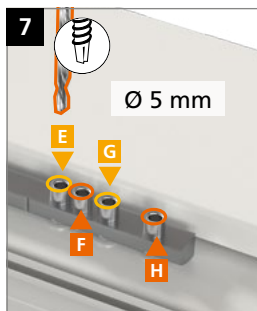
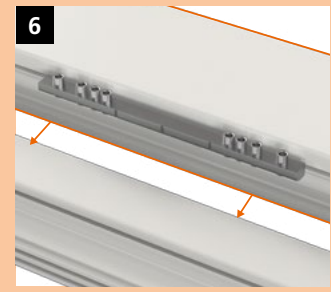
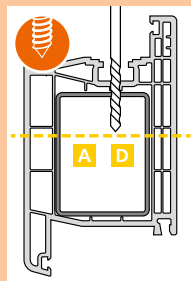
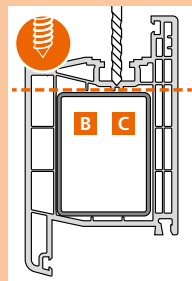
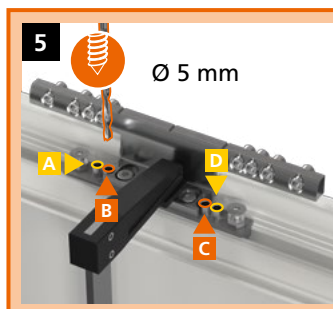
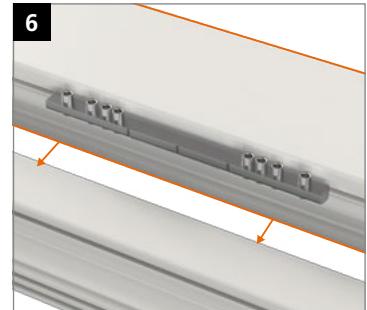
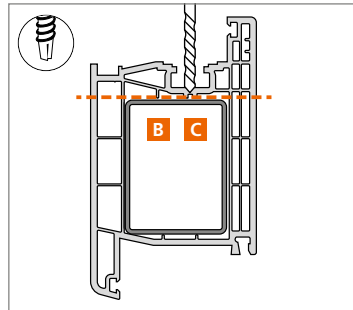
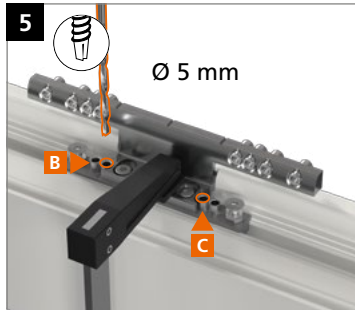

Montage des Türbands · Montage de la paumelle · Installing the hinge

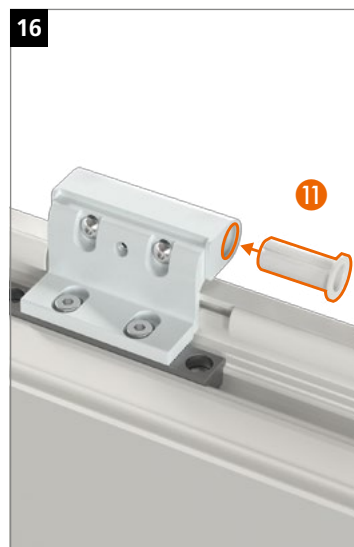
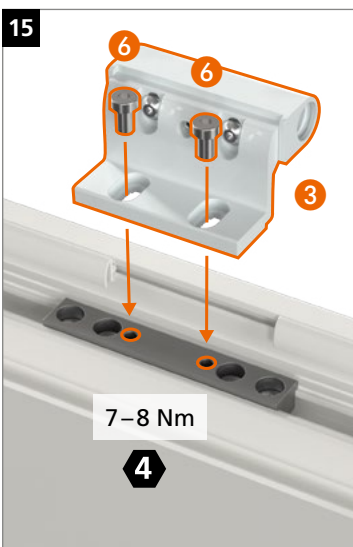
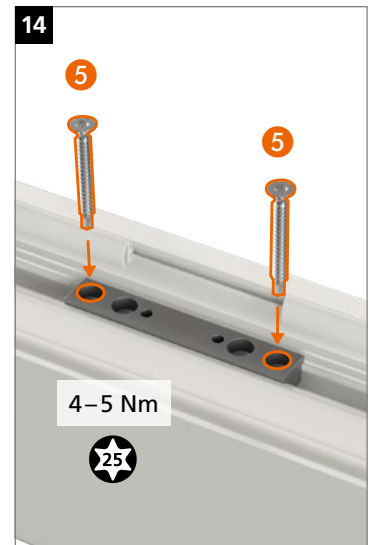
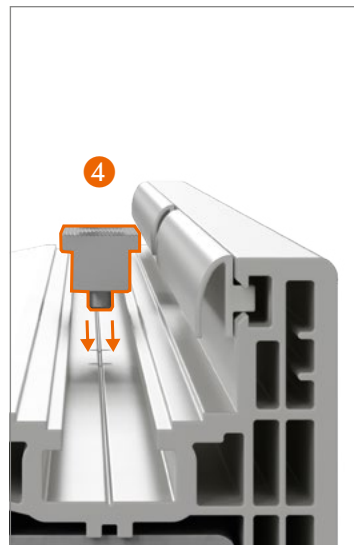
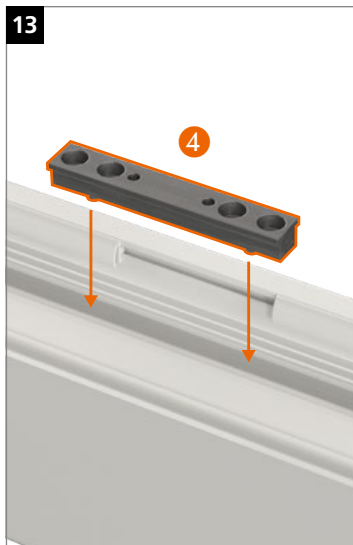
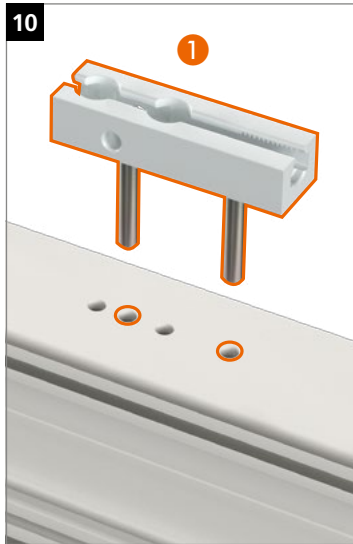

Montage des Türbands · Montage de la paumelle · Installing the hinge

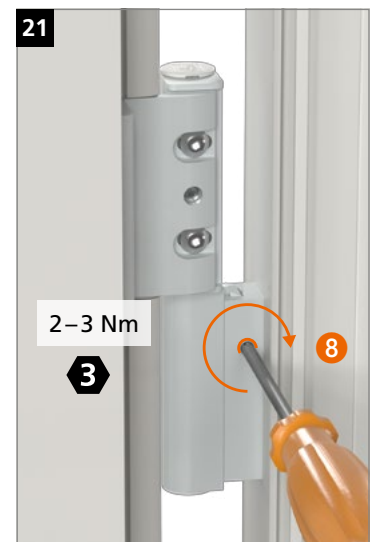
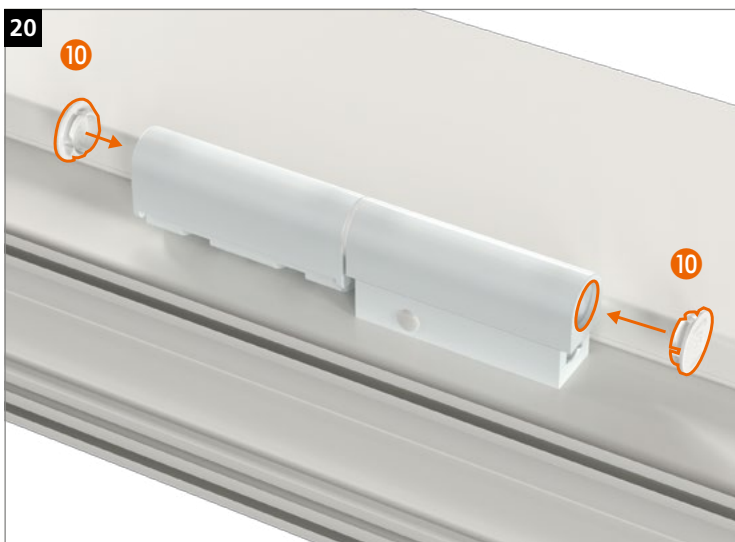
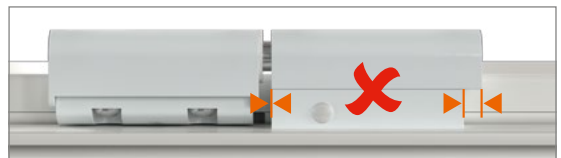
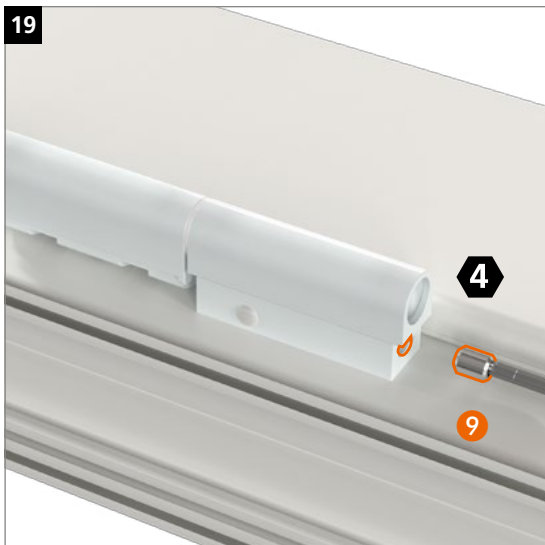
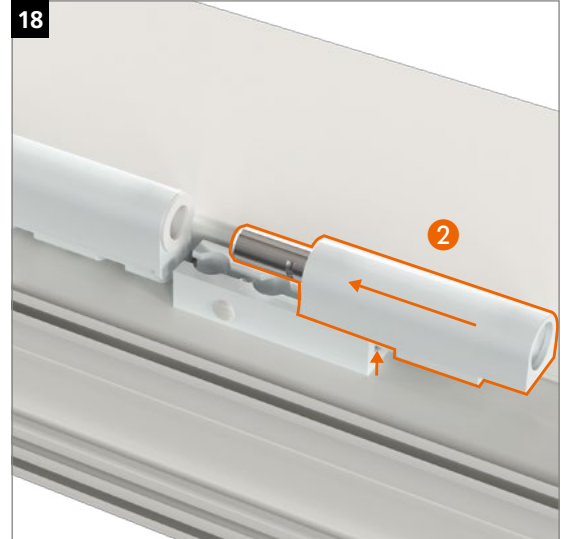
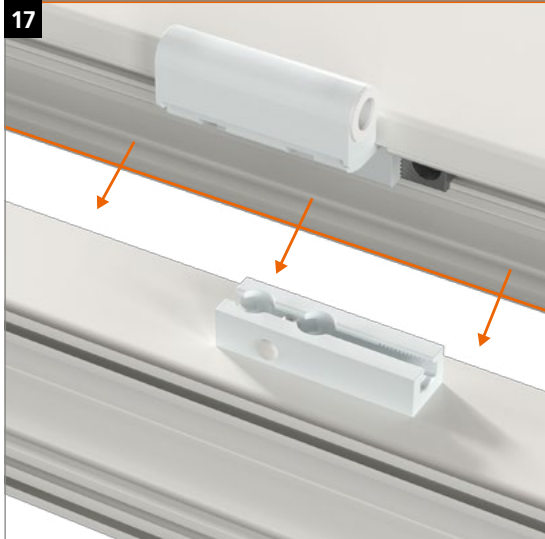

Einstellanleitung
Notice de réglage
Adjustment instructions

Verstellung der Bänder nur durch im
 Türenbau erfahrene Fachhandwerker.

Réglage et montage des paumelles
 uniquement par des professionnels qualifiés.

Adjustment and regulation only to be
 done by an experienced tradesman.



Höhenverstellung · Réglage en hauteur · Adjusting the height

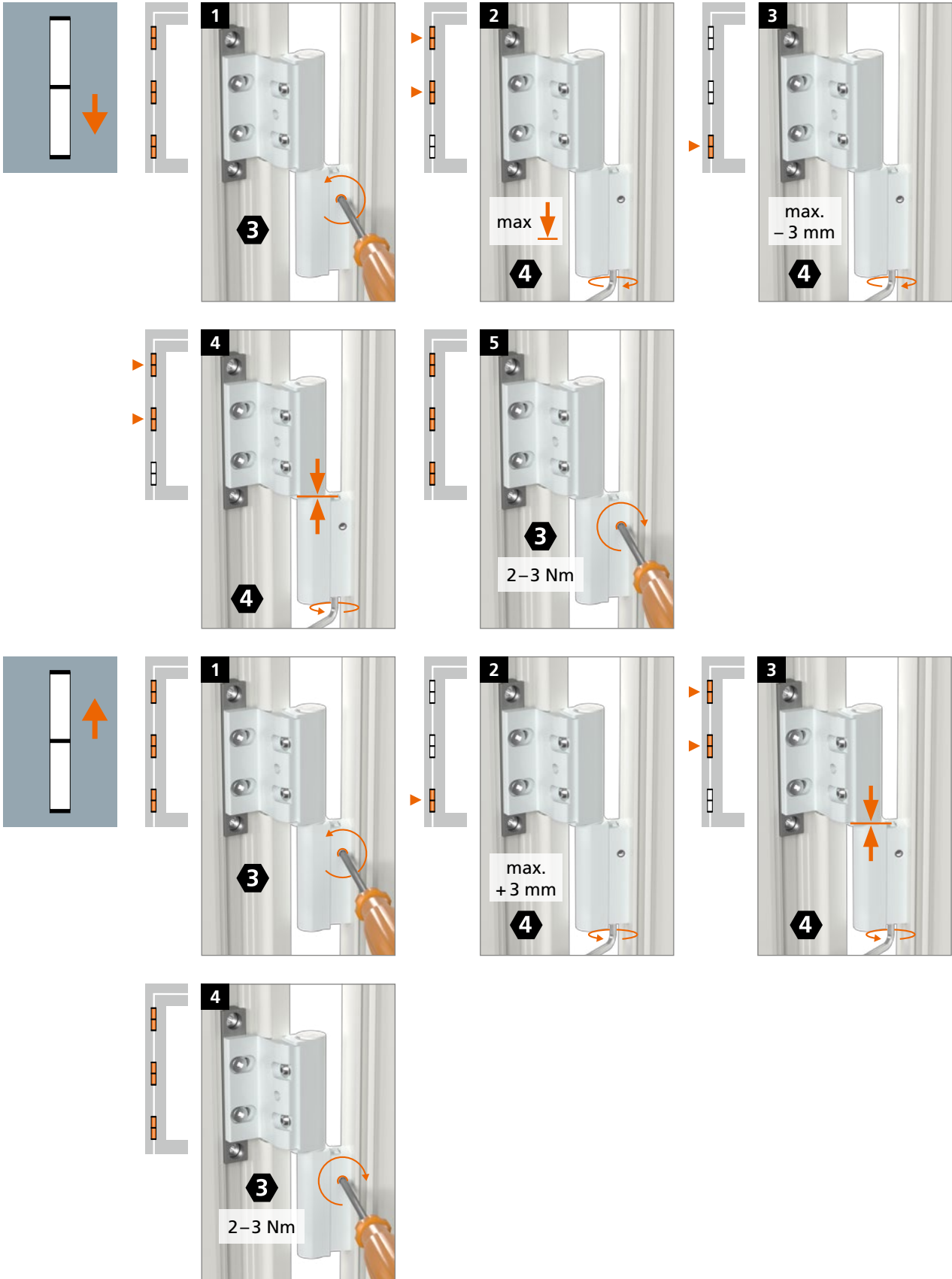

Einstellanleitung
Notice de réglage
Adjustment instructions

Verstellung der Bänder nur durch im
 Türenbau erfahrene Fachhandwerker.

Réglage et montage des paumelles
 uniquement par des professionnels qualifiés.

Adjustment and regulation only to be
 done by an experienced tradesman.



Horizontalverstellung · Réglage horizontal · Horizontal adjustment

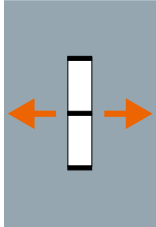

Dichtungsandruckverstellung · Réglage de la compression du joint d'étanchéité · Adjusting the sealing pressure

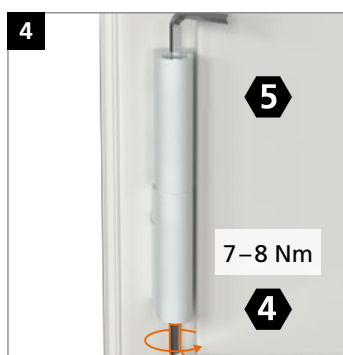
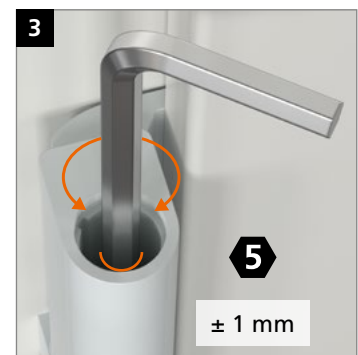
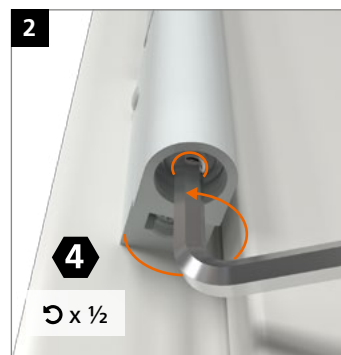
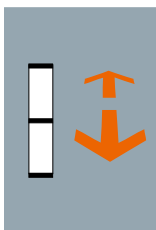



Dr. Hahn GmbH & Co. KG

Trompeterallee 162 – 170 · D-41189 Mönchengladbach
Postfach 400109 · D-41181 Mönchengladbach
Phone +49(0)2166 954-3 · E-Mail: sales@dr-hahn.com
www.dr-hahn.eu